

SDN™ Series Redundant Options

The SDN Series standard options allow for operation in a wide variety of applications. With the addition of an external redundancy module, the SDN can also be used for true redundant operation including 2N and N+x configurations.

All SDN units include built in current sharing for parallel and redundant operation. All models ending in P also include a DC OK status relay contact. The external modules SDN 2.5-20RED and SDN 30/40RED increase the reliability by isolating the supplies and adding more signal options. Paralleling for increased power does not require the use of these modules.

Module Compatibility

Two separate modules are available to provide the maximum flexibility in size, cost and signaling capability. Refer to the chart below for information on which module can be used for each SDN power supply.

Power Rating – A simple Yes or No indication that this module can or cannot handle the power rating of that power supply.

Input/Output Signals – Yes indicates that each power supply would have an independent relay contact to provide power supply status, and the DC bus output from the redundant module has it's own DC OK relay contact. Output only indicates that only the output of the redundant module would have a DC OK relay contact.



Features

- DC OK Relay Contact
- True Isolation
- High availability
- SDN features and quality

Applications

- Process Control
- Remote Location
- Critical Production

Redundancy Module Compatibility Chart

		Single Phase SDN Series				
		SDN 2.5–24–100P*	SDN 4–24–100P*	SDN 5–24–100P	SDN 10–24–100P	SDN 20–24–100P
SDN 2.5–20RED	Power Rating	Yes	Yes	Yes	Yes	Yes
	Input / Output Signals	Yes	Yes	Yes	Yes	Yes
SDN 30/40RED	Power Rating	Yes	Yes	Yes	Yes	Yes
	Input / Output Signals	Yes	Yes	Yes	Yes	Yes
		Three Phase SDN Series				
		SDN 5–24–480	SDN 10–24–480	SDN 20–24–480	SDN 30–24–480	SDN 40–24–480
SDN 2.5–20RED	Power Rating	Yes	Yes	Yes	No	No
	Input / Output Signals	Output Only	Output Only	Output Only	N/A	N/A
SDN 30/40RED	Power Rating	Yes	Yes	Yes	Yes	Yes
	Input / Output Signals	Yes	Yes	Yes	Yes	Yes

* Paralleling will violate Class 2 current limits.

SDN™ Redundant Series Specifications for SDN2.5-20RED and SDN 30/40RED

Catalog Number		
Description	SDN 2.5-20RED	SDN 30/40RED
Concept		
By means of a separate redundancy module, you can interconnect several identical SDN power supply units in a N+1 redundant mode. These external modules decouple the power supply outputs from each other so that, in case of failure, one power supply unit cannot overload the other units. The modules incorporate DC OK relay contacts. The switch on front of the SDN power supply should be placed in parallel mode (not single mode) when power supplies are used with redundant module.		
Electrical Characteristics		
Voltage		
-Nominal Value	24 Vdc	
-Max. Rated	35 V	
Voltage Drop		
-V _{in} -> V _{out}	Typ. 0.6 V	
Current Handling Capacity		
-Maximum Value	20 A	40 A
Inverse Battery Protection		
Yes		
Connection		
Via captive screw terminals		
-Connector size range	Solid: 16-10 AWG (1.5 - 6 mm ²) Stranded: 16-12 AWG (1.5 - 4 mm ²)	Solid: 16-5 AWG (1.5 - 16 mm ²) Stranded: 16-8 AWG (1.5 - 10 mm ²)
	Note: GND must be connected to module for voltage monitor to operate properly. See Connectors and Wiring diagrams on next page.	
Relay Contacts		
DC Okay Contacts (qty) description	(1) V _{out} "OK" - N.O. & N.C. Contact	(1) V _{out} "OK" - N.O. Contact (2) V _{in} "OK" - N.O. Contact
-Voltage Set Point	> 18 Vdc ±5%	
-Contact Rating	30 Vdc @ 2A / 250 V @ 2A	
DC OK LED		
	V _{out} "OK" Green LED	
-Voltage Set Point	> 18 Vdc ±5%	
Dimensions		
H x W x D – inches (mm)	4.88 in x 1.97 in x 4.55 in (124 mm x 50 mm x 116 mm)	4.88 in x 2.56 in x 4.55 in (124 mm x 65 mm x 116 mm)
Free Space for Ventilation – inches (mm)	Above/Below: 0.39 in. (10 mm) recommended Left/Right: 0.39 in. (10 mm) recommended	
Weight lbs (kg)	1.38 (625)	1.43 (646)
General		
Ambient Temperature	Storage: -25°C...+85°C Operation: -10°C...+60°C full power with operation to 70°C possible with a linear derating to half power from 60°C to 70°C (Convection cooling, no forced air required). Operation up to 50% load permissible with sideways or front side up mounting orientation. The relative humidity is < 90% RH, noncondensing.	

Wiring Diagram for SDN 30/40RED

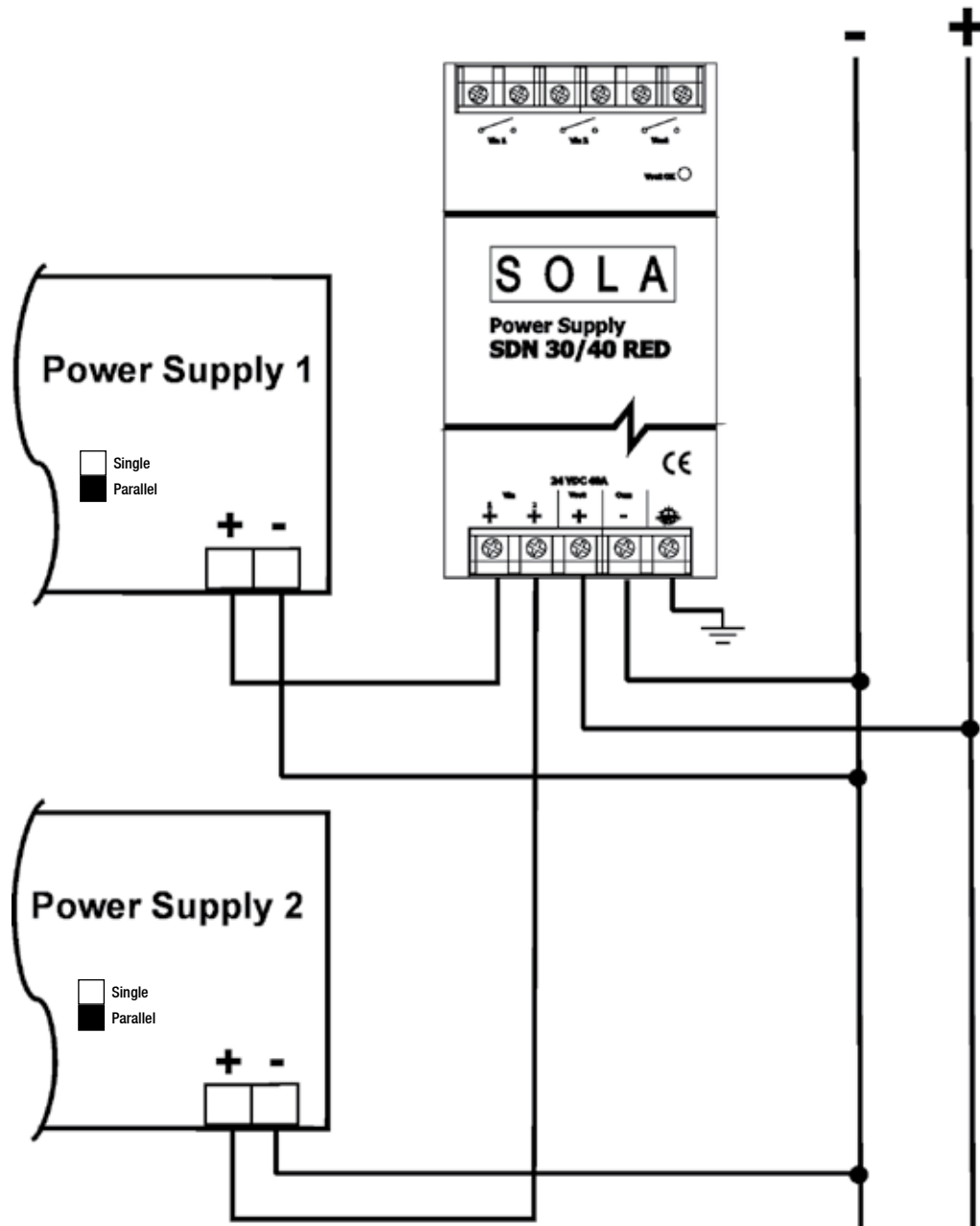

Notes:

1. The Common (marked "COM -") connection to the module is required for voltage monitoring (DC OK Contacts), and is not meant to be part of the current path from the power supply to the load.
2. Protective earth connection only provides protective ground to the metal case of the module. This connection is isolated from the positive and common connections.